



PIVOT SHUTTLE

Original Operational Instructions

This manual is intended to provide you with the information needed to get you on the trail. This guide will walk you through the steps necessary to set up all the components and become familiar with the Shimano STEPS E-bike System. This document contains some helpful diagrams and reference material to make sure you have everything necessary to maintain your Shuttle and enjoy it to the fullest.



Table of Contents

SECTION	PAGE
1. Quick Start Guide	1
- Suspension/Tire Set-up	1
- Adjusting Saddle Height	1
- Charging the Battery	1
- Powering the System ON and OFF	1
- Assist Switch and Shifter Function	2
- Operating the Cycle Computer	2
- Screen Display	2
2. Bike Set-up	3
- Setting Proper Sag	3
- Setting Compression Damping on the Fox DPX2	3
- Setting Open Mode Adjust on the Fox DPX2	3
- Setting Rebound Damping on the Fox DPX2	4
- Setting Air Pressure on the Fox 38 Fork	4
- Setting Compression Damping on the Fox 38 Fork	5
- Setting Rebound Damping on the Fox 38 Fork	5
- Recommended Tire Pressure	5
3. Charging	6
- Charging the Battery (On & Off the bike)	6
- Charger LED Lamp	6
4. Shimano STEPS System	7
- Connecting to E-Tube Project App	7
- Main Menu for E-Tube Project	7
- Customize Menu in E-Tube Project	7
- Assist Profiles in E-Tube Project	8
- Update Firmware Menu in E-Tube Project	8
- Maintenance Menu in E-Tube Project	8
- Removing the Battery	9
- Installing the Battery	9
5. Troubleshooting	10
- Cycle Computer Warning Codes	10
- Cycle Computer Error Codes	11
6. Schematics	12
- Shimano STEPS Schematic	12
- Small Parts Schematic	13
- Small Parts Table	13
- Wiring Diagrams	15
7. Additional Information	16
- Shimano STEPS System	16
- Pivot Shuttle	16
- Bicycle Safety	16
- Battery Safety	16



This "Quick Start Guide" provides the essential information to set up your bike.

Suspension/Tire Set-up

COMPONENT		QUICK START SETTING
Shock Air Pressure (by Body Weight)	Body Weight in [kg] to [bar]	$0.15 \times \text{Body Weight [kg]} + 2.4 \text{ [bar]}$
	Body Weight in [kg] to [psi]	$2.2 \times \text{Body Weight [kg]} + 35 \text{ [psi]}$
	Body Weight in [lbs] to [bar]	$0.07 \times \text{Body Weight [lbs]} + 2.4 \text{ [bar]}$
	Body Weight in [lbs] to [psi]	$\text{Body Weight [lbs]} + 35 \text{ [psi]}$
Shock Compression Damping		8 clicks in from OPEN (Team XTR Build Only)
Shock Rebound Damping		6 clicks in from OPEN
Fork Air Pressure		80 [psi] / 5.52 [bar]
Fork Compression Damping		HSC: 2 clicks in from OPEN; LSC: 5 clicks in from OPEN
Fork Rebound Damping		HSR: 3 clicks in from OPEN; LSR: 7 clicks in from OPEN
Front Tire Pressure		23 [psi] / 1.58 [bar]
Rear Tire Pressure		28 [psi] / 1.93 [bar]

Adjusting Saddle Height

- The seat post collar can be loosened and tightened with a 4mm hex wrench.
- Before raising or lowering the seat height, using a 2mm hex wrench, loosen the front bolt of the head tube cable port securing the dropper post housing.
- The dropper post cable should be routed through the cable port on the driveside of the head tube. This cable port cap is used to hold the dropper post cable and cycle computer wire in place.
- Be sure to re-tighten the cable clamp on the head tube cable port after adjusting the saddle height. Make sure not to pinch the cycle computer wire when tightening the cable port.

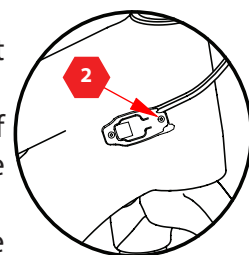

Charging the Battery

NOTE: The battery does not come fully charged and must be charged completely before the first use.

1. Locate the rubber cable port on the driveside of the headtube (fig. 1). The charging port is underneath the rubber cable management clamp. Pull back the sealing cover to access the charging terminal.
2. Locate the alignment pin in the charger. Insert the charging cable into the charging terminal, ensuring the cable and terminal are properly aligned. Thread the charging cable collar onto the terminal threads (fig. 2).
3. The display will illuminate briefly when the charger is properly connected. The charger LED lamp will glow red while charging, and glow green when charging is complete.
4. When done charging, unthread the cable from the terminal and close the sealing cover.

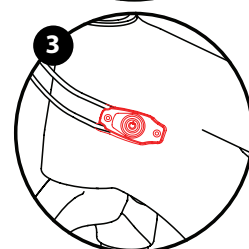
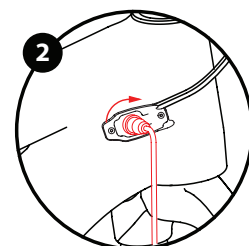
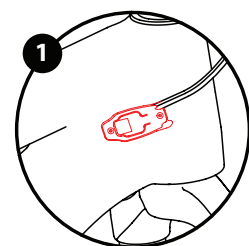

Powering the System ON and OFF

- The power button is located on the non-driveside of the headtube (fig. 3).
- Power the system on by pressing on the Power symbol molded into the rubber cable management clamp.
- Power cannot be turned on while the battery is charging.
- If the bike has not moved for 10 minutes, the power will shut off automatically.

Assist Switch and Shifter Function

- On start-up, the assist mode will be off. There are three levels of assistance: Eco, Trail, and Boost.
- The switch on the left side of the handle bar controls the level of assistance provided by the system.
- Walk Mode: This provides limited power to help move the bike while walking.
 - Press **Y1** until the Assist mode is off, then press and hold **Y1** to initiate Walk Mode.

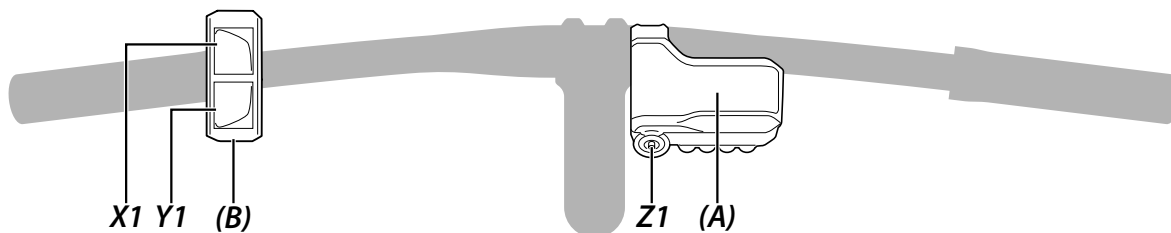

CYCLE COMPUTER (A)	
Z1	Cycles through display modes (Current Speed is default and will return after 60 seconds) <i>(Display Modes: Distance, Odometer, Range, Travel Time, Avg. Speed, Max. Speed, Cadence, Watts, Calories, Clock)</i>
ASSIST SWITCH (B)	
X1	Increase the level of assistance (Eco, Trail, and Boost)
Y1	Decrease the level of assistance (Press and hold for WALK mode)

Operating the Cycle Computer

- The following settings can be adjusted through the cyclecomputer:

MENU	
Clear	Clear Odometer
Clock	Set current time
Brightness	Adjust Display Brightness (1-5)
Beep	Toggle Display Sound
Unit	Choose Units (km/miles)
Language	Choose Display Language
Assist Customize	Choose Assist Profile (1 or 2)
Display Speed	Adjust Display speed
Exit	Exit the Menu

- Follow the below procedure to adjust the settings in the Menu:
 1. Press and hold **Z1** on cycle computer to enter the settings menu.
 2. Using **X1/Y1** scroll to setting to be adjusted. Press **Z1** to enter settings options.
 3. Using **X1/Y1** select desired setting adjustment.
 4. Press **Z1** to confirm adjustment. This will return to the menu screen.
 5. Using **X1/Y1** scroll to "Exit". Press **Z1** to return to the main display.

Screen Display



#	DISPLAY ITEM
1	Battery level indicator
2	Assist Gauge
3	Assist Mode Display*
4	Current Speed / Display Mode

*[ECO] mode automatically activates as remaining battery capacity declines



Setting Proper Sag

1. Always set sag with the *blue* compression damping adjust lever turned to the open position. (fig. 1)
2. Have the rider stand on the pedals, preferably with their hydration pack on, and have them sit down hard into the saddle to achieve accurate sag settings. The rider does not need to bounce up and down nor should they sit down gently. If they sit down hard once, the suspension will cycle well into the stroke and return to the natural sag setting with the rider in the saddle.
3. With the rider in the saddle and not moving, slide the O-ring up into position against the air can. (fig. 2)
4. Once the O-ring is set in place, have the rider slowly step off the bike so as not to move the O-ring.
5. Make adjustments to the sag by removing or adding air so that steps 2-4 result in the O-ring lining up with the red line on the sag indicator (fig. 3). It will be necessary to cycle the shock after adding or subtracting air before re-checking sag as the large Evol negative air chamber will need to equalize pressure with the main chamber each time air is added or removed. You can do this by pushing down on the saddle several times to compress the shock past the sag point.

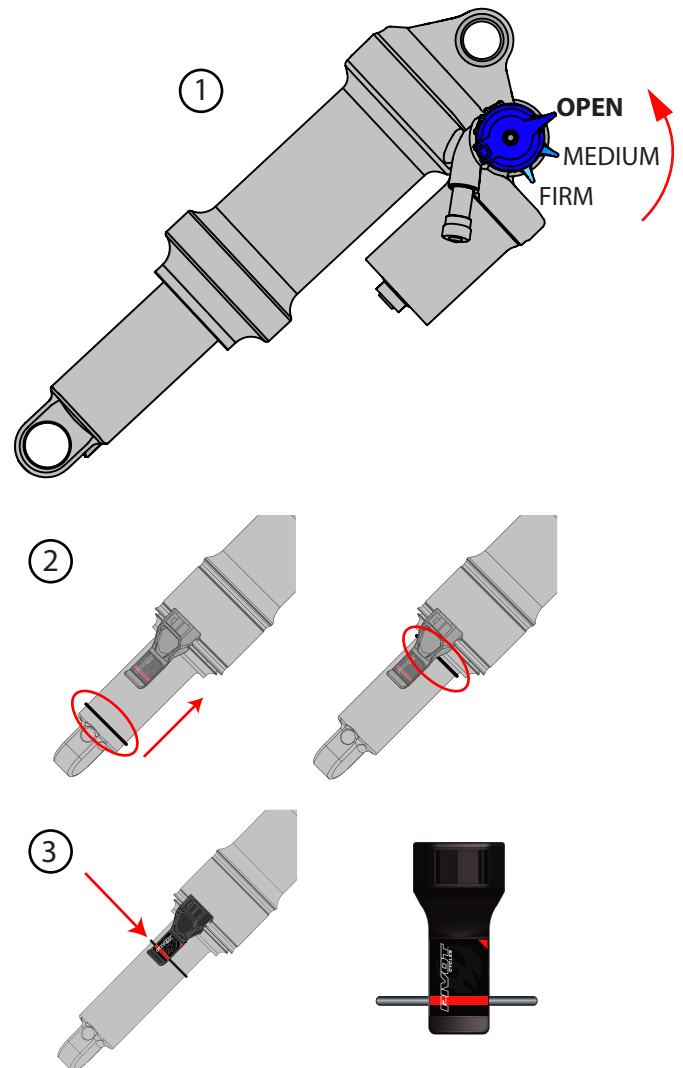

Setting Compression Damping on the Fox DPX2

- The compression damping lever is a tuning tool to adjust compression support.
- All bikes can be run in the open position at all times and still perform well.
- Riders under 82 [kg] (180 [lbs]) will generally run the shock in the open position most of the time.
- Riders over 82 [kg] (180 [lbs]) and aggressive riders may prefer the middle setting for more mid-stroke support.
- The firmest setting is best suited for riding to the trail, long fire road climbs, and smooth XC courses.

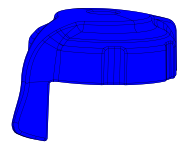

Setting Open Mode Adjust on the Fox DPX2

- The Open Mode Adjust screw fine tunes the compression damping in the open position.
- The adjustment screw is a 3mm hex screw inside the top of the compression damping lever.
- This adjuster offers 10 additional fine tune adjustments for the open mode.
- Turning the screw clockwise will increase low speed compression damping; turning the screw counter-clockwise will decrease low speed compression damping.
- Most riders will find 8 clicks from full open is a good starting point.

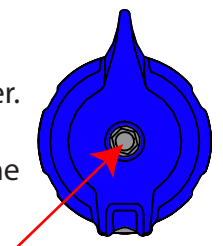

Setting Rebound Damping on the Fox DPX2

- Rebound is set from the most open (fully counter-clockwise) position.
- The rebound setting is determined by the air pressure in the shock.
- Refer to the table below for the suggested rebound setting. The number in the chart refers to how many clicks in (clockwise) from the open setting the rebound should be set.

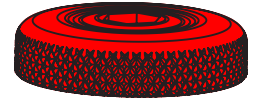

AIR PRESSURE		SUGGESTED REBOUND SETTING
[bar]	[psi]	
< 8.3	<120	3 (11)
8.3 - 9.7	120-140	4 (10)
9.7 - 11	140-160	5 (9)
11 - 12.4	160-180	6 (8)
12.4 - 13.8	180-200	7 (7)
13.8 - 15.2	200-220	9 (5)
15.2 - 16.5	220-240	10 (4)
16.5 - 17.9	240-260	12 (2)
17.9 - 19.3	260-280	13 (1)
19.3 - 20.7	280-300	CLOSED

Clicks from OPEN (Clicks from CLOSED)

Setting Air Pressure on the Fox 38 Fork

- Fox recommends setting sag between 15% and 20% of the total fork travel. The Shuttle comes with a 160mm fork, so the proper sag measurement is 24.0 - 32.0mm.
- The air pressure in the Fox 38 fork should not exceed 8.3 [bar] (120 [psi]).
- To achieve the proper sag, reference the chart below for an initial starting point.

RIDER WEIGHT		FOX 38 AIR PRESSURE
[kg]	[lbs]	
55 - 59	120 - 130	72 [psi] / 5.0 [bar]
59 - 64	130 - 140	76 [psi] / 5.2 [bar]
64 - 68	140 - 150	80 [psi] / 5.5 [bar]
68 - 73	150 - 160	84 [psi] / 5.8 [bar]
73 - 77	160 - 170	89 [psi] / 6.1 [bar]
77 - 82	170 - 180	93 [psi] / 6.4 [bar]
82 - 86	180 - 190	97 [psi] / 6.7 [bar]
86 - 91	190 - 200	102 [psi] / 7.0 [bar]
91 - 95	200 - 210	106 [psi] / 7.3 [bar]
95 - 100	210 - 220	110 [psi] / 7.6 [bar]
100 - 105	220 - 230	114 [psi] / 7.9 [bar]
105 - 109	230 - 240	119 [psi] / 8.2 [bar]
109 - 114	240 - 250	123 [psi] / 8.5 [bar]

Setting Compression Damping on the Fox 38 Fork

- Only available on Team XTR Builds
- To set compression, start from the open (or fastest) position by turning the *black* (LSC) dial & *blue* (HSC) dial counterclockwise until it stops clicking.
- Turn the *black* (LSC) dial clockwise 5 clicks & turn the *blue* (HSC) dial clockwise 2 clicks.
- The recommended starting points and may need to be adjusted based on rider weight. Lighter riders may prefer less compression damping (fewer clicks from open).

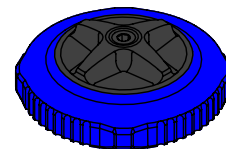

Setting Rebound Damping on the Fox 38 Fork

- To set rebound, start from the open (or fastest) position by turning both *red* rebound dials on the bottom of the right fork leg counterclockwise until it stops clicking.
- Refer to the chart below for the recommended settings when setting rebound.

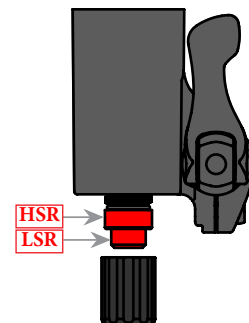

RIDER WEIGHT	SUGGESTED REBOUND SETTING	
	LSR / HSR	
120-130 [lbs]	3 / Open	(12 / 10)
130-140 [lbs]	4 / Open	(11 / 10)
140-150 [lbs]	5 / 1	(10 / 9)
150-160 [lbs]	6 / 2	(9 / 8)
160-170 [lbs]	7 / 3	(8 / 7)
170-180 [lbs]	8 / 4	(7 / 6)
180-190 [lbs]	8 / 4	(7 / 6)
190-200 [lbs]	9 / 5	(6 / 5)
200-210 [lbs]	9 / 5	(6 / 5)
210-220 [lbs]	10 / 6	(5 / 4)
220-230 [lbs]	11 / 7	(4 / 3)
230-240 [lbs]	11 / 7	(4 / 3)
240-250 [lbs]	12 / 8	(3 / 2)

Clicks from OPEN (Clicks from CLOSED)

Recommended Tire Pressure

- Tire pressure is an important factor on having the bike ride properly. If the tire pressure is too high, the tire will not conform to ground, reducing traction. If the tire pressure is too low, the tire could pinch flat.
- It is important to have an accurate pressure gauge when setting tire pressure; preferably a digital gauge with a 0.03 [bar] (0.5 [psi]) accuracy.
- The recommended tire pressure will vary slightly based on rider weight, riding style, and terrain.
- Some riders may find it helpful to start a ride at a slightly higher pressure than recommended and let out a little air throughout the course of the ride until you find your ideal riding tire pressure.

RECOMMENDED TIRE PRESSURE	
FRONT	REAR
1.58 [bar] / 23 [psi]	1.93 [bar] / 28 [psi]

Charging the Battery

- The battery for the Shuttle can be charged while installed, but can also be charged after removing the battery from the frame.
- In order to charge the battery off the bike, you will need the charging adapter (PN 5J.E4C0C.020) which can be ordered through Pivot Cycles.

Charging the Battery on the Bike

1. Locate the rubber cable port on the driveside of the downtube near the headtube (*fig 1*).
2. The charging port is underneath the rubber cable management clamp and can be accessed through the sealing cover. Pull back the sealing cover to expose the charging terminal.
3. Look for the alignment pin in the charger and insert the charging cable into the charging terminal, ensuring the cable and terminal are properly aligned.
4. Secure the cable to the terminal by threading the charging cable collar onto the terminal threads (*fig 2*).
5. The display will illuminate briefly when the charger is properly connected. The charger LED lamp will glow red while charging, and glow green when charging is complete.
6. When done charging, unthread the cable from the terminal and close the sealing cover on the rubber cable management cap.

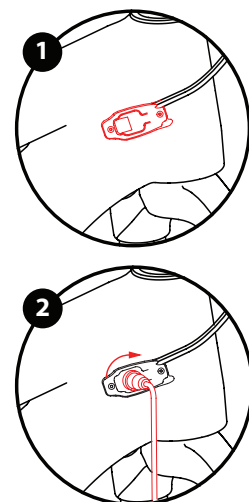

Charging the Battery off the Bike

1. Remove the battery from the bike. Instructions for this procedure can be found on page 9 in this document.
2. Look for the alignment pin in the charger and insert the charging cable into the charging adapter, ensuring the cable and adapter are properly aligned.
3. Secure the cable to the adapter by threading the charging cable collar onto the adapter threads.
4. Orient the adapter terminals with the terminal block on the battery and plug the adapter into the battery.
5. The charger LED lamp will glow red while charging, and glow green when charging is complete. The current charge level will be displayed on the battery LEDs just above the terminal block on the battery.
6. When done charging, remove the adapter from the battery terminal block.

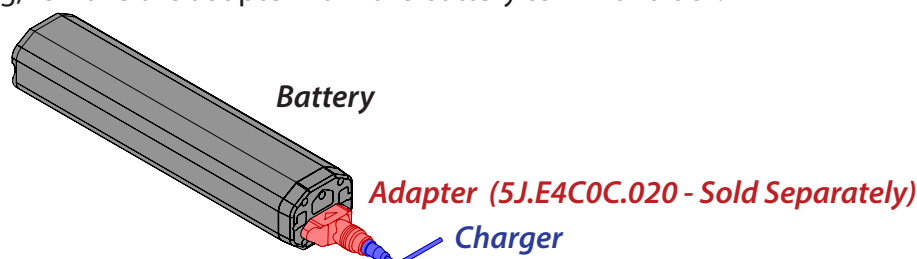

Charger LED Lamp

- After charging has started, the LED lamp on the charger lights up.

Charger LED Lamp

LED INDICATOR	DESCRIPTION
Lit Up (GREEN)	Battery Charging Complete
Lit Up (RED)	Battery Charging

Connecting to E-Tube Project App

- The display layout and switch operation can be customized through the Shimano E-Tube Project App.
- The Shimano E-Tube Project can be accessed via the Shimano E-Tube Project app available in the App Store
- The E-Tube Project app is compatible with both Android and Apple devices.

Connecting via the E-Tube Project app:

1. Before setting up a connection, turn on the Bluetooth connectivity of the smart phone or tablet.
2. Open the E-Tube Project app and then power up the Shuttle.
3. Once the bike has been powered on, press the large plus sign (+) on the "Get started" opening screen.
4. A list of nearby devices will be listed on the screen. Choose your bike.
5. When the connection is successful, a list of "confirmed units" will appear. These are all the devices connected to the Shuttle. The units listed should include: the battery, drive unit, cyclecomputer, & assist switch.
6. If all the connected units appear, press "OK" to confirm that all devices are shown.
7. To disconnect, press the "Disconnect" button at the bottom of the screen.

Main Menu for E-Tube Project

- The main menu to the E-Tube Project has three main menus that are relevant for the consumer to know how to navigate and operate: Update, Customize, & Maintenance. These are listed at the top of the app.
- The app will open to the "Customize" menu. The other functions can be accessed by swiping left or right.

Customize Menu in E-Tube Project

- The Customize menu lists the components available for customization: Assist, Drive Unit, Assist Switch, & Cyclecomputer
- The tables below show the available options within the Customize menu.

E-BIKE		DESCRIPTION
Assist*	Assist Character	Adjust Assist Character for each Assist Level (Eco, Trail, Boost)
	Max. Torque	Adjust Maximum Torque for each Assist Level (Eco, Trail, Boost)
	Assist Start	Adjust how quickly assistance is provided for each Assist Level (Eco, Trail, Boost)
Drive Unit	Max. Assist Speed	Adjust Max Assist Speed (Max. 20 mph) & Speed correction percentage
	Display Speed	Allows adjustment of display speed to match speed shown on third party unit

*Assist features can be saved into 2 profiles for easy access to preferred settings

SWITCH		DESCRIPTION
Assist Switch*	X1	Customize the functions of the buttons on the assist switch
	Y1	Customize the functions of the buttons on the assist switch

*X1/Y1 Buttons are the Upper/Lower button on the Assist Switch. See Page 2 for the handlebar diagram.

DISPLAY		DESCRIPTION
Cyclecomputer	Unit	Change display units from International standards to US Customary standards
	Shift	Toggle display modes (Travel Time, Avg. Speed, Max. Speed, Cadence, Time)
	Time (Auto/Man.)	Set the current time (Either manually or automatically)
	Beep	Toggle system sound
	Brightness	Adjust display brightness
	Language	Select display language
	Name	Create a custom name for your bike
	Passkey	Change passkey for accessing the E-Tube app

Assist Profiles in E-Tube Project

- The E-Tube Project allows saving two profiles with different assist characteristics for different terrain.
- To customize a profile:
 1. Under the "Customize" menu, select "Assist". (The active profile will be displayed on this button.)
 2. At the top of the "Assist customize" screen, the current profile will be displayed. To choose the other profile, tap the profile name (or the double arrows) and it will alternate to the other profile.
 3. To customize the selected profile, choose "Eco", "Trail", or "Boost" to customize each assistance level.
 4. For each assistance level, the Assist Character, Max. Torque, & Assist Start features can be customized within the range defined by the white slider. Move the colored dot (corresponding to the selected assistance level), to the desired value for that feature.
- The Shuttle comes with two preloaded profiles:
 1. Pivot Factory Default: Optimized for balance and control
 2. Maximum assistance permitted for all levels

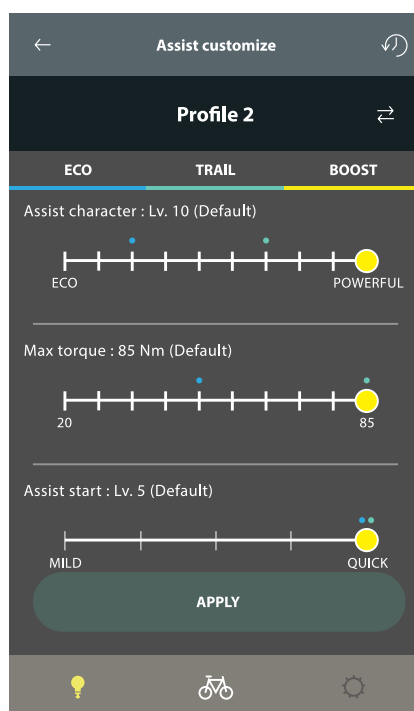
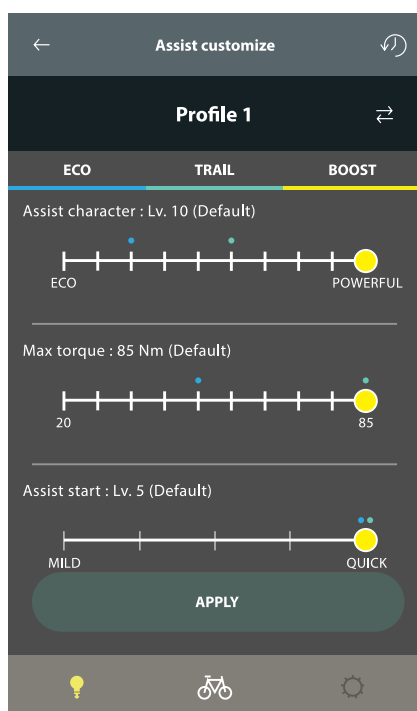

← Return to Customize menu

↺ Reset to Default settings

↔ Switch between profiles

● ECO settings

● TRAIL settings

● BOOST settings

💡 Go to "Update" menu

🚲 Go to "Customize" menu

⚙️ Go to "Maintenance" menu

Update Firmware Menu in E-Tube Project

- There is an "Update" menu option listed at the top of the app homescreen. To access this feature tap on the word "Update".
- Under the Update menu option, all connected devices are listed, and the app will display if they are running the latest firmware, or if it needs to be updated.
- There is also an "Update All" button. By pressing this button, the software automatically searches for and downloads any update for the system.
- Once the program has completed any updates, each component of the Shimano STEPS E-bike System will be listed with the corresponding version of the latest firmware for that component.

Maintenance Menu in E-Tube Project

- There is a "Maintenance" menu option listed at the top of the app homescreen. To access this feature tap on the word "Maintenance".
- Under the Maintenance menu option, there is an Error log which will track system errors to provide better insight into system performance and catalogue any previous issues.



Removing the Battery

- The battery may need to be removed to swap batteries or to charge the battery if there is no power supply near the bike.
- This procedure may be easier with the bike upside down.

1. Using a M5 hex wrench, remove the two pins securing the battery cover to the frame.
2. Remove the cover from the frame. The battery will remain in the frame after the cover is removed.
3. Slowly apply forward pressure to unseat the battery from the terminal block located inside the downtube. CAUTION: The amount of force required may cause the battery to move forward quickly once it disconnects from the terminal block.
4. Reach through the fork stanchions and carefully pull the battery through the fork to remove the battery. The battery is heavy and this action may require two hands.

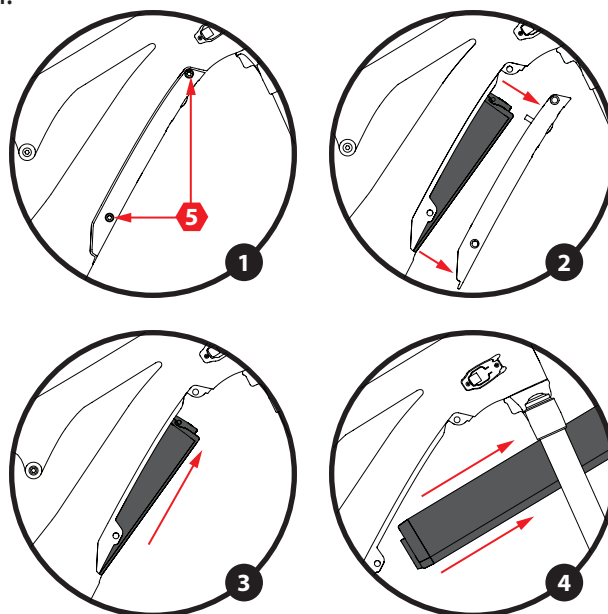

Installing the Battery

- To install the battery, reverse the removal procedure from above

1. Check the orientation of the battery before installing the battery.
2. Carefully route the battery through the fork stanchions and into the downtube.
3. Apply downward pressure on the battery to fully seat the battery into the terminal block
4. Rest the front of the battery on the bracket attached to the cover and align the back of the cover with the edge of the battery cavity. Lift the front of the cover into place.
5. Grease the pins and install them to the frame (starting with the forward pin) while apply pressure to the battery cover. The pins are different lengths. The shorter pin is installed in the front and the longer pin is installed in the back.
6. Torque the pins to 10 Nm.

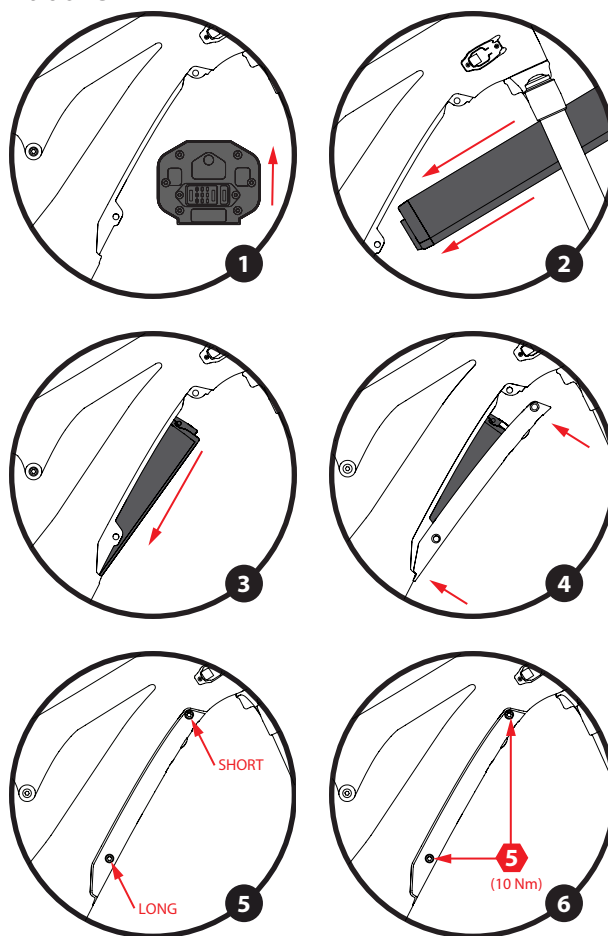

Cycle Computer Warning Codes

- Warnings may appear on the cycle computer display if the system detects an issue.
- The warning code will clear once the issue is resolved.
- If any issues persist after the suggestions below, contact the place of purchase.



CODE	ISSUE	OPERATIONAL RESTRICTION	REMEDY
W010	Drive unit operation temperature is higher than normal	Power assistance may be lower than usual	Stop using the assist function until the drive unit temperature drops.
W011	Traveling speed cannot be detected	Maximum speed may be lower than usual	Check that the speed sensor is installed correctly.
W013	Torque sensor was not initialized properly	Power assistance may be lower than usual	Turn the power off and back on again.
W020	Battery operation temperature is higher than normal	No system functions will start	Leave the battery in a cool place until the temperature decreases sufficiently.
W032	Shifting unit installed differs from unit configured in system	Unable to perform gear shifting	Update shifting configuration in E-Tube Project app.
W10000	Drive unit operation temperature is higher than normal	Power assistance may be lower than usual	Stop using the assist function until the drive unit temperature drops.
W10100	Traveling speed cannot be detected	Maximum speed may be lower than usual	Check that the speed sensor is installed correctly.
W103	Sensor initialization could not be completed normally	Power assistance may be lower than usual	Turn the cranks in reverse two or three times.
W10300	Sensor initialization could not be completed normally	Power assistance may be lower than usual	Turn the cranks in reverse two or three times.
W104	Power was turned off due to current leakage detected	Power assistance will not be provided while riding	Remove components from drive unit and turn on to find faulty component.
W10400	Power was turned off due to current leakage detected	Power assistance will not be provided while riding	Remove components from drive unit and turn on to find faulty component.
W10500	Unexpected power disconnection was detected	There are no restricted assist functions while displayed	Check the power cord for damage. Turn the power off and back on again.
W20000	Battery operation temperature is higher than normal	No system functions will start	Leave the battery in a cool place until the temperature decreases sufficiently.
W30200	Shifting unit installed differs from unit configured in system	Unable to perform gear shifting	Update shifting configuration in E-Tube Project app.

Cycle Computer Error Codes

- An error message may appear on the cycle computer if the system detects an issue.
- If any issues persist after the suggestions below, contact the place of purchase.



CODE	ISSUE	OPERATIONAL RESTRICTION	REMEDY
E010	A system abnormality was detected in the drive unit	Power assistance is not provided during riding	Turn the power off and back on again.
E01000 - E01004	A sensor abnormality was detected in the drive unit	Power assistance is not provided during riding	Contact the place of purchase.
E01010 - E01011	A sensor abnormality was detected in the drive unit	Power assistance is not provided during riding	Contact the place of purchase.
E01020 - E01022	A sensor abnormality was detected in the drive unit	Power assistance is not provided during riding	Contact the place of purchase.
E01030	A sensor failure was detected in the drive unit	Power assistance is not provided during riding	Contact the place of purchase.
E01040 - E01042	A malfunction was detected in the drive unit	Power assistance is not provided during riding	Contact the place of purchase.
E01050 - E01051	A sensor failure was detected in the drive unit	Power assistance is not provided during riding	Contact the place of purchase.
E013, E034 & E03400	An abnormality was detected in the drive unit's firmware	Power assistance is not provided during riding	Connect to the E-Tube Project app and restore or update the firmware.
E014	An abnormal vehicle speed signal was detected from the speed sensor	Power assistance is not provided during riding	Check that the speed sensor is correctly positioned.
E020 & E02000	A communication error between the battery and drive unit was detected	Power assistance is not provided during riding	Check that the cable between the drive unit and battery is properly connected.
E021	Battery connected to the drive unit is not supported	Power assistance is not provided during riding	Turn the power off and back on again.
E022	The battery connected does not conform with system standards	No system functions will start	Turn the power off and back on again.
E023	An electrical failure was detected inside the battery	No system functions will start	Turn the power off and back on again.
E025	The battery does not recognize the drive unit	No system functions will start	Confirm the drive unit is compatible. Check the power cord for damage.
E030	Shifting unit installed differs from unit configured in system	Power assistance is not provided during riding	Update shifting configuration in E-Tube Project app.
E033	Current firmware is not supported by this system	Power assistance is not provided during riding	Connect to the E-Tube Project app and update the firmware.
E035 & E03500	An abnormality was detected in the vehicle settings	Power assistance is not provided during riding	Connect to the E-Tube Project app to check if the settings and vehicle status differ.
E043	Part of the system firmware may be corrupted	Power assistance is not provided during riding	Contact the place of purchase to restore the system firmware.
E044	Error caused by system configuration	Power assistance is not provided during riding	Contact the place of purchase.
E050 & E05000	An abnormal vehicle speed signal was detected from the speed sensor	Power assistance is not provided during riding	Check that the speed sensor is correctly positioned.



Shimano STEPS E-bike System Schematic

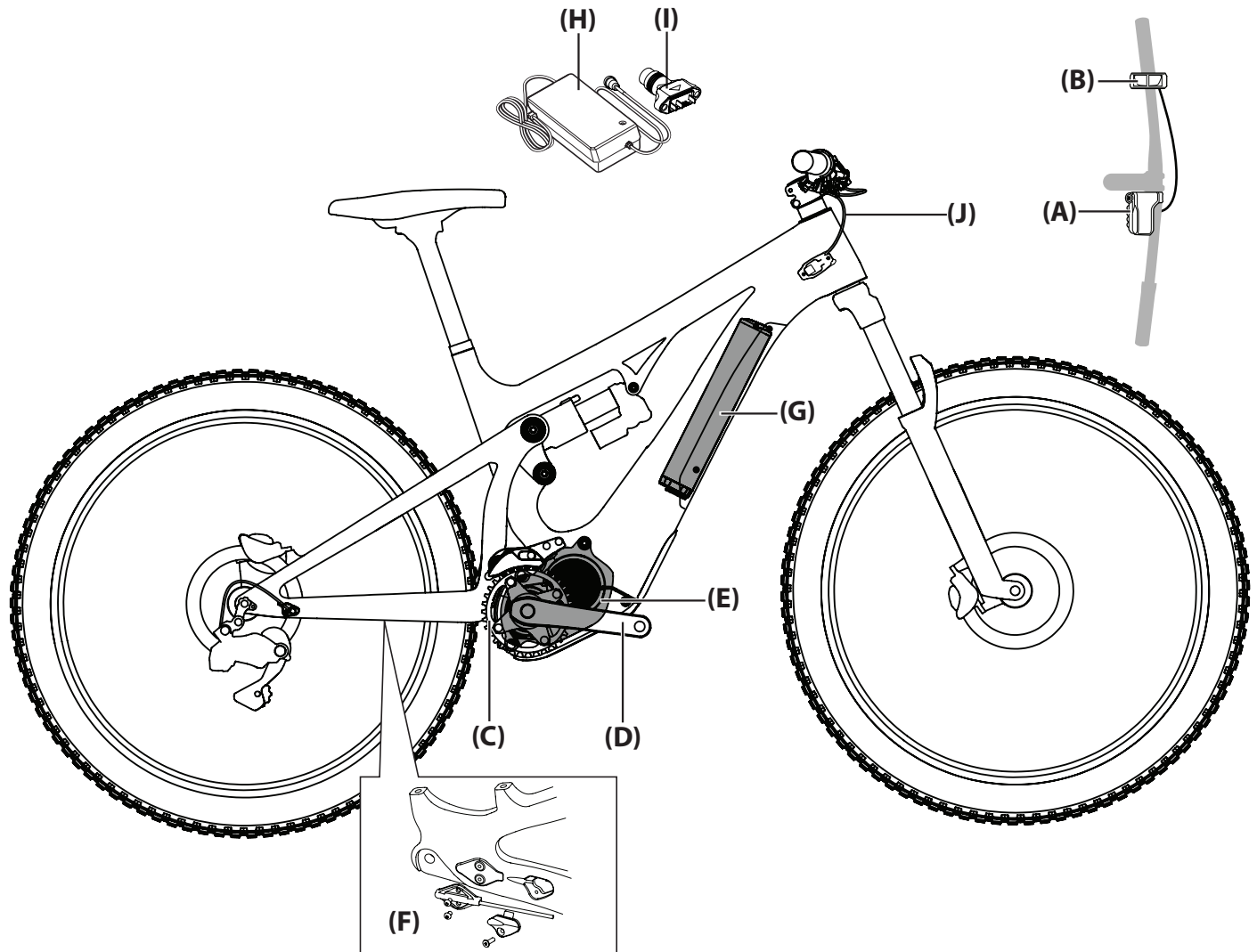

LETTER	PART DESCRIPTION	PART NAME
A	Cycle Computer	SC-EM800A
B	Assist Switch	SW-EM800-L
C	Front Chainring	SAMOX NWP201-34T
D	Crank Arm	FC-M8150
E	Drive Unit	DU-EP800
F	Speed Sensor	EW-SS301
G	Battery	DARFON 720 Wh
H	Battery Charger	DARFON E4C0C
I	Battery Charger Adapter (For Off-the-bike Charging - Sold Separately)	DARFON 5J.E4C0C.020
J	Cycle Computer E-Tube Wire (1000mm)	EW-SD300



Small Parts Schematic

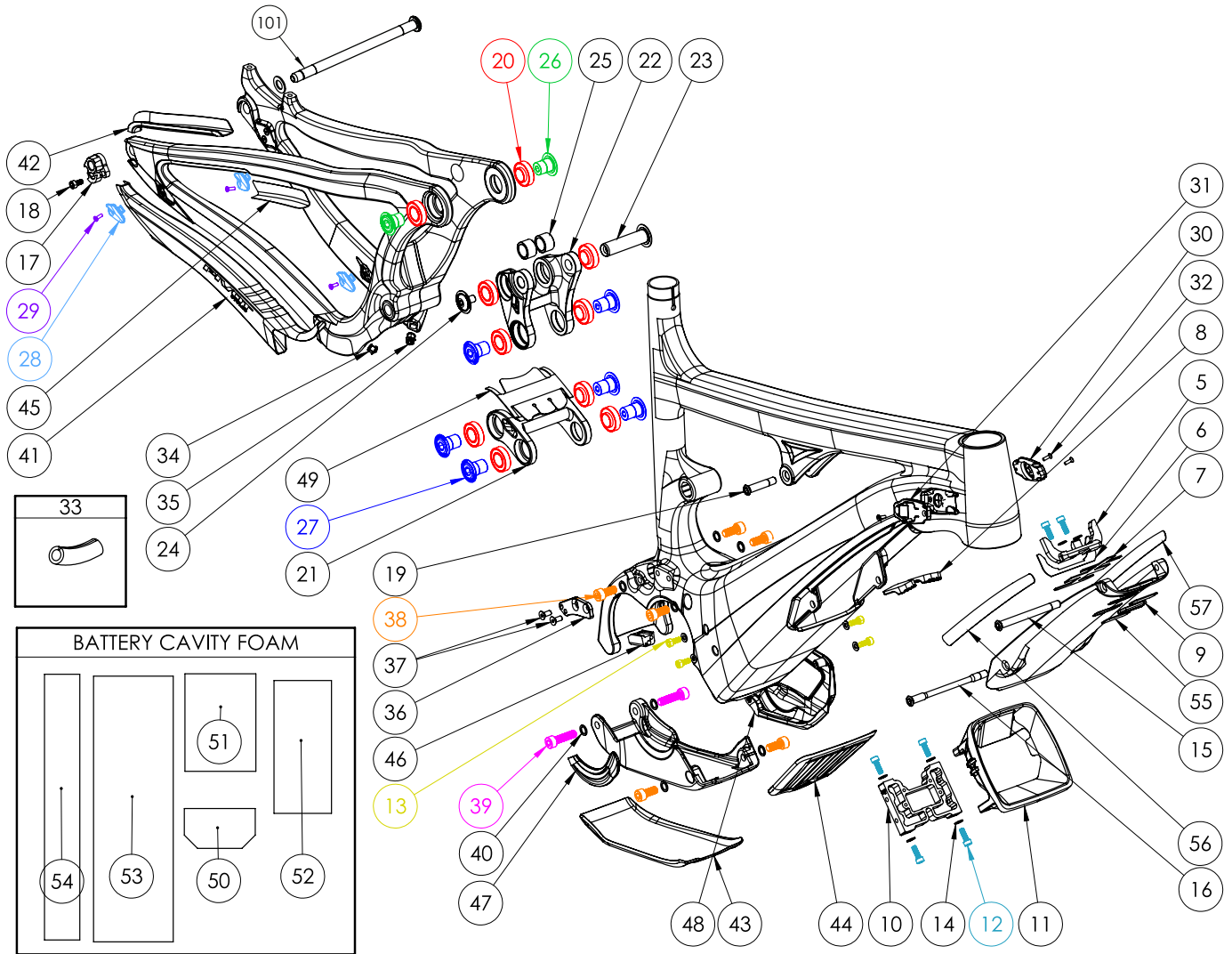

Small Parts Table (Continued on next page)

NUMBER	PART NAME	DESCRIPTION	TORQUE	*
5	FP-MNT-BRCKT-BATT-V1-R1	Front Battery Bracket		
6	FP-SPC-FRNT-BRKT-V1-R1	Rubber Spacer for Front Bracket		
7	FP-SPC-BATT-CVR-V1-R1	Rubber Spacer for Battery Cover		
8	FP-BMP-BATT-BUMPER-V1-R1	Battery Bumpers		
9	FP-MNT-FRNT-BATT-V2-R1	Front Battery Bracket Mounting Plate		
10	FP-MNT-REAR-BATT-V1-R1	Rear Battery Bracket Mount		
11	FP-GDE-SHUTTLE-BATT-V1-R1	Rubber Battery Guide		
12	FP-SCW-SCK-M5*15	M5x15 Sockethead Screw	Until Snug	L
13	FP-SCW-SCK-M5*12	M5x12 Sockethead Screw	7 Nm (5 lb-ft)	L
14	FP-WSH-5I*100*1W	M5 Washers		
15	FP-BLT-M8*85-BLK-V1-R1	Front Battery Cover Bolt	10 Nm (7 lb-ft)	G
16	FP-BLT-M8*108-BLK-V1-R1	Rear Battery Cover Bolt	10 Nm (7 lb-ft)	G
17	FP-RDH-TA-12MM-BLK-V3	Rear Derailleur Hanger 12mm TA		
18	FP-SCW-SCK-M5*10	M5x10 Socket Screw for RD Hanger	5 Nm (4 lb-ft)	G
19	FP-BLT-M8*38-BLK-V2	M8x38 Front Shock Bolt	13 Nm (10 lb-ft)	A

Small Parts Table (Continued)

NUMBER	PART NAME	DESCRIPTION	TORQUE	*
20	FP-BRG-6902-LLUMAXECCN	28mm 6902 Ext'd Max-E Bearing		
21	FP-LNK-LL-50MM-V1	50mm Out-to-Out Lower Link		
22	FP-LNK-UL-70MM-DSM-V1	70mm Direct Shock Mount Upper Link		
23	FP-PIN-SHK-M8*150-BLK	15x57mm M8 Rear Shock Pin		
24	FP-BLT-M8*12-BLK	M8x12 Rear Shock Bolt	13 Nm (10 lb-ft)	L
25	FP-WSH-SPC-M15*13	M15x13 Rear Shock Spacer		
26	FP-BLT-M14*17-BLK-V1-R2	M14x17 Upper Link Bolt	35 Nm (27 lb-ft)	L
27	FP-BLT-M14*20-BLK-V2-R2	M14x20 Lower Link Bolt	35 Nm (27 lb-ft)	L
28	FP-CLM-MECH-FRM-V1	Internal Routing Cable Clamp		
29	FP-SCW-FLT-M3*10	M3x10 Cable Clamp Screw (Included w/ Clamp)		
30	FP-CVR-PWR-BUTTON-V1-R1	Head Tube Cable Guide and Power Button Cover		
31	FP-CVR-CHARGE-PORT-V1-R1	Head Tube Cable Guide and Charging Port Cover		
32	FP-SCW-FLT-M3*12	M3x12 Cable Clamp Screw		
33	FP-CLM-DI2-SLV-BLK-V1	DI2 Wire Sleeve for Cable Clamps		
34	FP-GDE-DI2-7*8*5*3.9	7x8mm Cable Guide Ext'd		
35	FP-GDE-DUAL-7*13*5-V1	Extended Dual Wire/Housing Guide		
36	FP-MNT-CG-V1	Chain Guide Mounting Plate		
37	FP-SCW-FLT-M5*12	M5x12 CG Mounting Screw	5 Nm (4 lb-ft)	L
38	FP-SCW-SCK-M8*18-R1	M8x18 Motor Mounting Screw	13 Nm (10 lb-ft)	L
39	FP-SCW-SCK-M8*30-R1	M8x30 Motor Mounting Screw	13 Nm (10 lb-ft)	L
40	FP-WSH-8*120*1W	M8 Motor Mount Bolt Washer		
41	FP-PRO-SHTLE-CS-V1-R1	E-Bike Carbon Chainstay Protector		
42	FP-PRO-SHTLE-SS-V1-R1	E-Bike Carbon Seatstay Protector		
43	FP-PRO-SHTLE-SP-V1-R1	E-Bike Carbon Skid Plate Protector		
44	FP-PRO-SHTLE-BC-V2-R1	E-Bike Carbon Battery Cover Protector		
45	FP-PRO-SHTLE-SS-EXT-V1-R1	E-Bike Extended Seatstay Protector		
46	FP-GDE-MECH-MTR-V1-R1	Cable Guide for Mechanical Spec		
47	FP-CVR-MOTOR-DS-V1-R1	Drive side Motor Cover		
48	FP-CVR-MOTOR-NDS-V1-R1	Non-drive side Motor Cover		
49	FP-PRO-50MM-LL-V1-R1	50mm Lower Link Protector		
50	FP-PRO-FOAM-80*45-V1-R1	Battery Cavity Foam (80x45)		
51	FP-PRO-FOAM-80*110-V1-R1	Battery Cavity Foam (80x110)		
52	FP-PRO-FOAM-150*65-V1-R1	Battery Cavity Foam (150x65)		
53	FP-PRO-FOAM-300*90-V1-R1	Battery Cavity Foam (300x90)		
54	FP-PRO-FOAM-300*40-V1-R1	Battery Cavity Foam (300x40)		
55	FP-CVR-SHUT-FRNT-BRCKT-V1-R1	Front Bracket Plate Cover		
56	FP-GKT-BATT-DS-V1-R1	Battery Cover Gasket (Driveside)		
57	FP-GKT-BATT-NDS-V1-R1	Battery Cover Gasket (Non-Driveside)		
58	FRAME SIZE STICKER - XS/SM/MD/LG/XL	Frame Size Sticker		
101	157MM THROUGH AXLE V4	157mm Rear Axle	15 Nm (11 lb-ft)	G

*	PRODUCT TYPE	RECOMMENDED PRODUCT
G	Grease	Motorex Bike Grease 2000
A	Anti-Seize	Motorex Copper Paste
L	Thread Locker	Loctite 243



Shuttle Wiring Diagram: Team XTR Build

- The diagrams below will help illustrate how the wires are to be routed through the internal cable guides and how the handlebar switches are attached to the cycle computer.
- The routing shown below will help minimize the likelihood of pinching a wire when removing and installing the motor for maintenance purposes.

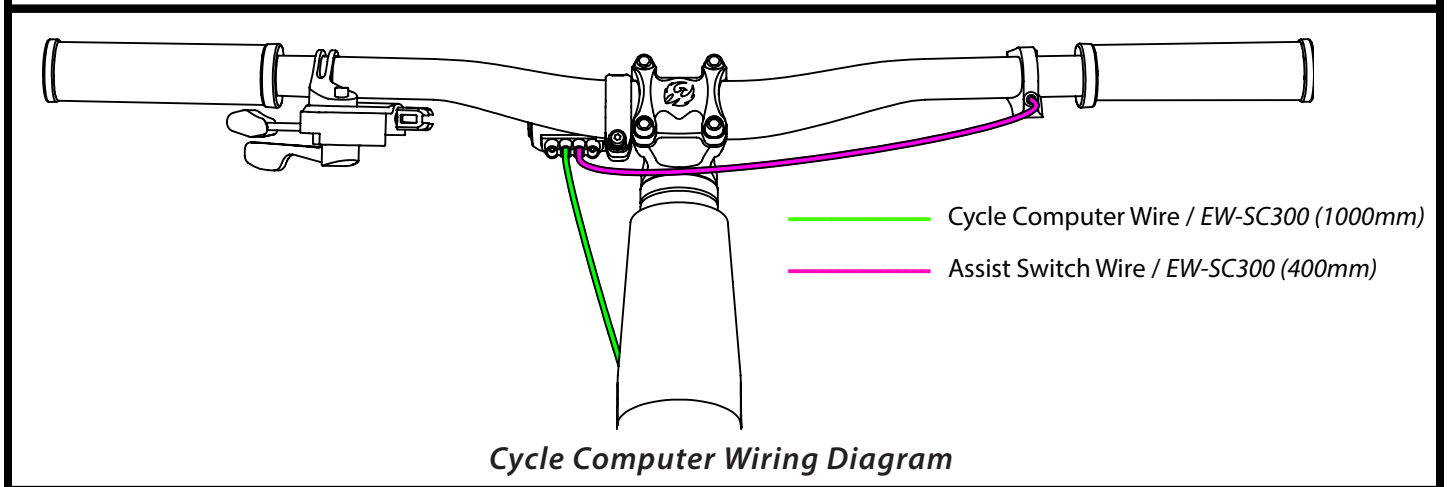
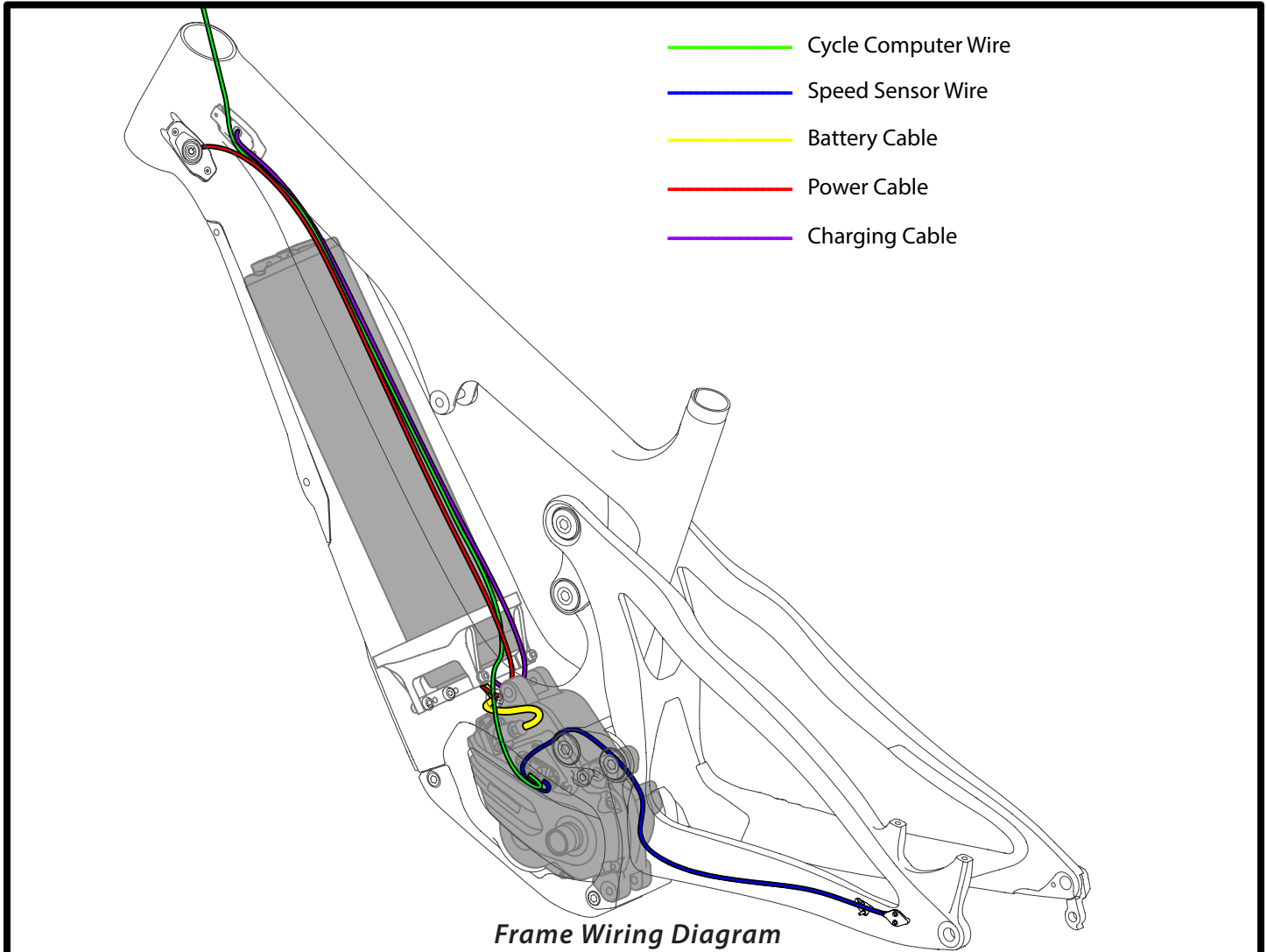

Shimano STEPS E-bike System

- Additional information regarding operation and functionality of the Shimano STEPS E-bike System can be found at: <http://si.shimano.com/#/>
- To download the E-tubes Project software to fully utilize the connectivity of the Shimano STEPS E-bike System visit: <http://e-tubeproject.shimano.com/>

Pivot Shuttle

- For FAQs and additional technical documents regarding the maintenance of the Pivot Shuttle can be found at: <http://www.pivotcycles.com/bike/shuttle/>

Bicycle Safety

- This bike is not designed or equipped for use on public roads. Before it can be used on public roads it must be fitted with the legally prescribed equipment. It is designed to be used off-road, but not for competitions. The manufacturer and dealer accept no liability for damage resulting from any use beyond this definition and/or failure to comply with the safety information and instructions in this user guide. This applies particularly to, but not limited to, the use of this bike in competitions, overloading, and the failure to properly rectify faults. Intended use also includes conformance with the specified operating, service, and repair conditions in the user guide. Fluctuations in the consumption and power of the battery and a reduction of capacity with increasing age are common and technically unavoidable, and as such, do not constitute material defects.

Battery Safety

- Batteries are subject to the dangerous goods regulations. Private users are permitted to transport them on the road without further conditions. If transported by commercial third parties (e.g. by air freight, logistics companies, or postal service) special conditions apply to packing and labeling. For questions about transporting batteries, please contact your local Pivot dealer.
- Damaged batteries must not be charged, used, or transported. They can explode and cause serious burns or fires. Gases can be released and irritate the airways. Ensure there is a supply of fresh air and consult a doctor in the event of discomfort. Liquid can escape and cause skin irritation. Avoid contact with this liquid, but in case of accidental contact, wash off with water. If the liquid gets into the eyes, flush out with water and seek medical attention.
- Batteries must not be submerged in water. There is a risk of explosion. Do not attempt to extinguish a burning battery with water, only the surrounding burning material. For burning batteries, use a Class D Fire Extinguisher. If it is possible to take the battery safely outside, smother the fire with sand. You do not need to worry that you are in danger when riding in the rain; the battery is protected from moisture and condensation.
- Clean the battery with a dry or, if at all, a slightly moist rag. Do not direct the water jet of a high pressure cleaner at the rechargeable battery or submerge the battery into water, as there is a risk of water entry and/or short-circuit.
- For more information on the proper handling of your rechargeable battery see the system instructions of your drive manufacturer.
- Charge your battery only with the supplied charger. Do not use the charger of any other manufacturer, not even when the connector of the charger matches your rechargeable battery. The rechargeable battery can heat up, catch fire or even explode!
- Keep the rechargeable battery and the charger out of the reach of children!

Battery Safety (Continued)

- We recommend that you charge your battery only during the day and only in dry rooms which have a smoke or a fire detector; but not in your bedroom. Place the battery during the charging process on a big, non-inflammable plate made of ceramics or glass! Unplug the battery once it has been charged up.
- Keep the rechargeable battery and the charger away from moisture and water during the charging process to exclude electric shocks and short circuits.
- Do not use a rechargeable battery or a charger that is defective. If you are in doubt or if you have any questions, contact your Pivot dealer.
- Do not expose your battery or the charger to the blazing sun during charging.
- Do not charge any other electrical devices with the supplied charger of your Pivot e-bike.
- The drive is not approved for steam cleaning, high-pressure cleaning or cleaning with a water hose. The contact of the electrics or the drive with water can destroy the units. The individual drive components can be cleaned with a soft rag and neutral detergents. You may use a moist rag, but not excessive water. Keep the rechargeable battery dry and do not submerge it. Risk of explosion.
- Make sure your rechargeable battery does not show any damage, i.e. cracks, breakages or discolorations at the contact points. Do not use a battery with such damage. Bring a damaged battery to your Pivot dealer at once.
- Make sure your rechargeable battery is in sound condition. Do not open, disassemble or crush the battery. Risk of explosion!
- Make sure your rechargeable battery is not exposed to mechanical impacts.
- Keep your battery away from fire and heat. Risk of explosion!
- Batteries must not be short-circuited. Therefore store them in a safe storage area and make sure the battery is not short-circuited accidentally (e.g. with metal or another battery). In addition, rechargeable batteries must not be stored inappropriately, e.g. in a box or in a drawer where they can be short-circuited by other conductive materials or where they can short-circuit each other. Do not deposit any objects in the storage area (e.g. clothes).
- Make sure to use the battery only for the Pivot e-bike for which it is designed.
- Remove the rechargeable battery if you do not use your Pivot e-bike for a long period of time (e.g. during the winter season). Store the rechargeable battery in a dry room at temperatures between 5 - 20°C (41 - 68°F) . The state of charge should be 50 - 70% of the charging capacity. Check the state of charge if the rechargeable battery is left unused for more than two months and recharge it in between, if necessary, to 50%.
- The battery does not come charged and must be charged completely before the first use.
- When removing the charger from the outlet or the port, pull on the plug, not the cord.
- When charging the battery, plug the cord into the wall outlet first, and then into the battery.
- Be sure that the charger is on a flat and stable surface, when charging.
- Do not leave the battery fully depleted for an extended period of time. This will cause the battery to deteriorate and reduce the battery capacity.
- Keep the rechargeable battery and the charger away from moisture and water during the charging process to avoid electric shocks and short circuits.
- Keep the charger and battery out of reach of children.
- Do not use a battery or a charger that is defective. If you are in doubt, contact your Pivot dealer.
- If the rechargeable battery or the charger (or parts of it) must be replaced, only use original spare parts. Contact your Pivot dealer.
- Charge the battery at an ambient temperature of approximately 20°C (68°F). Therefore, before starting the charging, wait until the temperature of the battery has increased or decreased after a ride in cold or hot weather.

Battery Safety (Continued)

- Do not dispose of your rechargeable battery in the normal household rubbish! It must be disposed of according to battery disposal regulations. Therefore, sellers of new rechargeable batteries must provide collection of old batteries and appropriate disposal. If you are in doubt or if you have any questions, contact your Pivot dealer.
- When the battery is fully charged, remove the charger.
- Observe the notes on the respective labels on the rechargeable battery or on the charger.

